



FEATURES

- Configurable input for RTD, TC, mV, Resistance and Potentiometer
- Galvanic isolation at 1500 Vac
- Voltage output configurable from 0 up to 10 Vdc
- Configurable by Personal Computer by cable CVPROG
- High accuracy
- On-field reconfigurable
- EMC compliant – CE mark
- Suitable for DIN B in-head mounting
- Option for DIN rail mounting in compliance with EN 50022 (DIN RAIL Option)



GENERAL DESCRIPTION

The isolated converter DAT1135 is able to execute many functions such as: measure and linearisation of the temperature characteristic of RTDs sensors, conversion of a linear resistance variation, conversion of a voltage signal even coming from a potentiometer connected on its input. The DAT1135 is able to measure and linearise the standard thermocouples with internal cold junction compensation. The measured values are converted in a 0÷10 V signal. The device guarantees high accuracy and performance stability both in time and in temperature. The programming of the DAT1135 is made by a Personal Computer using the software DATESOFT and the cable CVPROG, both developed and provided by DATEXEL. By DATESOFT, that runs under the operative system "Windows™", it is possible to configure the transmitter to interface it with the most used sensors.

For Resistance and RTDs sensors it is possible to program the cable compensation with 3 or 4 wires; for Thermocouples it is possible to program the Cold Junction Compensation (CJC) as internal or external.

It is possible to set the minimum and maximum values of input and output ranges in any point of the scale, keeping the minimum span shown in the table below.

It is available the option of alarm for signal interruption (burn-out) that allows to set the output value as high or low out of scale.

On the device is provided a function that allows the user to set a programmable filter up to 30 seconds to reduce eventual sudden variations of the input signal.

The 1500 Vac isolation between input and power supply/output eliminates the effects of all ground loops eventually existing and allows the use of the converter in heavy environmental conditions found in industrial applications.

It is housed in a self-extinguish plastic enclosure suitable for DIN B in-head mounting.

Moreover (by proper mounting kit) it is possible to mount the DAT1135 on DIN rail.

USER INSTRUCTIONS

The converter DAT1135 must be powered by a direct voltage from 18 up to 30V applied to the terminals +V and -V.

The output signal 0÷10 V is measurable between the terminals O(OUT) and -V.

The input connections must be made as shown in the section "Input connections".

To configure, calibrate and install the converter refer to sections " DAT1135: configuration and calibration" and "Installation Instructions".

TECHNICAL SPECIFICATIONS (Typical at 25 °C and in nominal conditions)

Input type	Min	Max	Min. span	Input calibration (1)	Output Load resistance – Rload	
TC(*) CJC int./ext. J K S R B E T N	-200°C	1200°C	100°C	RTD > of ±0.1% f.s. or ±0.2°C	Voltage output ≥ 5 KΩ	
	-200°C	1300°C	100°C	Low res. > of ±0.1% f.s. or ±0.15 Ω	Short-circuit current 26 mA max	
	0°C	1750°C	400°C	High res. > of ±0.2% f.s. or ±1 Ω	Response time (10÷ 90%) about 200 ms	
	0°C	1750°C	400°C	mV, TC > of ±0.1% f.s. or ±10 uV		
	0°C	1800°C	400°C	Output calibration Voltage ± 5 mV	Output filter programmability Selectable from 0.2 to 30 s.	
	-200°C	1000°C	100°C			
	-200°C	400°C	100°C	Input impedance TC, mV ≥= 10 MΩ	Power supply Power supply voltage 18 .. 30 Vdc Current consumption 10 mA max. Reverse polarity protection 60 Vdc max	
	-200°C	1300°C	100°C			
	RTD(*) 2,3,4 wires Pt100 Pt1000 Ni100 Ni1000	-200°C	850°C	50°C	Linearity (1) TC ± 0.2 % f.s. RTD ± 0.1 % f.s.	Isolation voltage Input – Pow. supply/Output 1500 Vac, 50 Hz, 1min.
		-200°C	185°C	30°C		
-60°C		180°C	50°C	Line resistance influence TC, mV ≤=0.8 uV/Ohm RTD 3 wires 0.05%/Ω (50 Ω balanced max.) RTD 4 wires 0.005%/Ω (100 Ω balanced max.)		
-60°C		150°C	30°C			
Voltage mV mV mV		-100mV	+90mV	5 mV	RTD excitation current Typical 0.350 mA	
	-100mV	+200mV	10 mV			
	-100mV	+800mV	20 mV			
Potentiometer (R nom. < 50 KΩ)	0%	100%	5%	CJC comp. ± 0.5°C	Housing Material PC + ABS V0 Mounting DIN B head or bigger Weight about 50 g. Dimensions Ø = 43 mm ; H = 24 mm	
	0 Ω	500 Ω	50 Ω			
RES. 2,3,4 wires	0 Ω	2000 Ω	500 Ω	Thermal drift (1) Full scale ± 0.01% / °C CJC ± 0.01% / °C	EMC (for industrial environments) Immunity EN 61000-6-2 Emission EN 61000-6-4	
	0 Ω	2000 Ω	500 Ω			
Output type Direct voltage Reverse voltage	0 V	10 V	1 V	Burn-out values Max. Fault value about 11.1 V Min. Fault value about -0.65 V		
	10 V	0 V	1 V			

(1) referred to input Span (difference between max. and min. values)

(*) For temperature sensors it is possible to set the input range also in F degrees; to made the conversion use the formula: °F = (°C*9/5)+32)

DAT 1135: CONFIGURATION

Notice: before to execute the next operations, check that the drivers of the cable CVPROG in use have been previously installed in the Personal Computer.

- 1) Remove the protection plastic cap on DAT1135.
- 2) Connect the two plugs of cable CVPROG to the Personal Computer (USB plug) and to the device (uUSB plug) .
- 3) Run the software DATESOFT. Set the COM port assigned to the CVPROG cable by the Operative System.
- 4) Set the parameters of configuration .
- 5) Program the device.

- CALIBRATION CONTROL

With software DATESOFT running and device powered:

- 1) Connect on the input a calibrator setted with minimum and maximum values referred to the electric signal or to the temperature sensor to measure.
- 2) Set the calibrator at the minimum value.
- 3) Verify that the device provides on output the minimum set value.
- 4) Set the calibrator at the maximum value.
- 5) Verify that the device provides on output the maximum set value.

INSTALLATION INSTRUCTIONS

The device DAT1135 is suitable for direct DIN B in-head mounting. The converter must be fixed inside the probe by the proper kit. By apposite stirrup, provided on request, it is possible to mount the device on DIN rail in compliance with EN-50022. It is necessary to install the device in a place without vibrations; avoid to routing conductors near power signal cables .

DIN rail mounting (DIN RAIL Option)

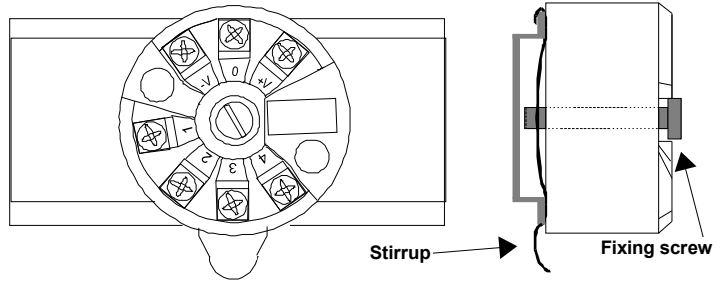

DAT1135 CONNECTIONS

INPUT CONNECTIONS

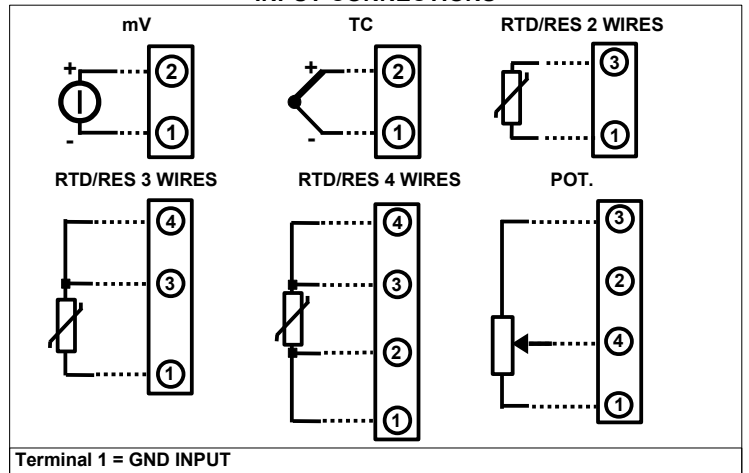

POWER SUPPLY CONNECTIONS

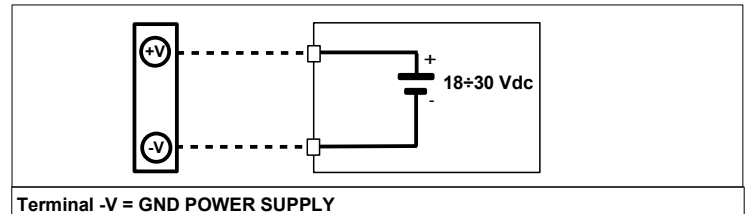

OUTPUT CONNECTIONS

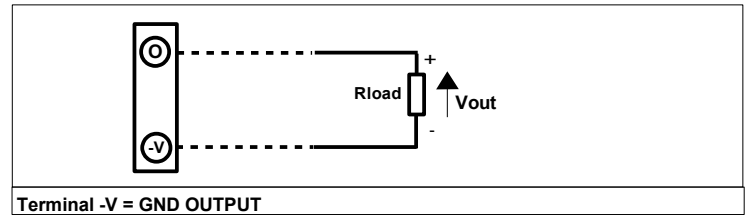

ISOLATIONS STRUCTURE



CONFIGURATION BY CABLE CVPROG

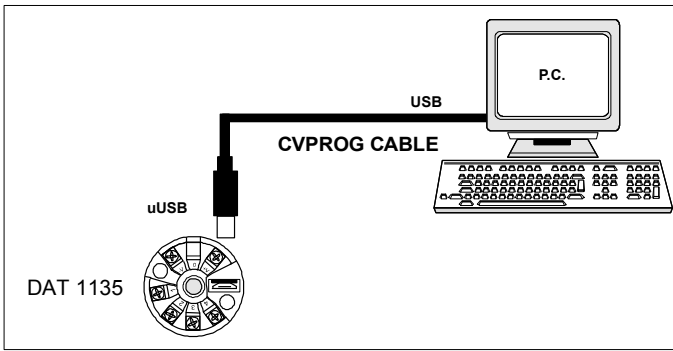

DIN B in-head mounting

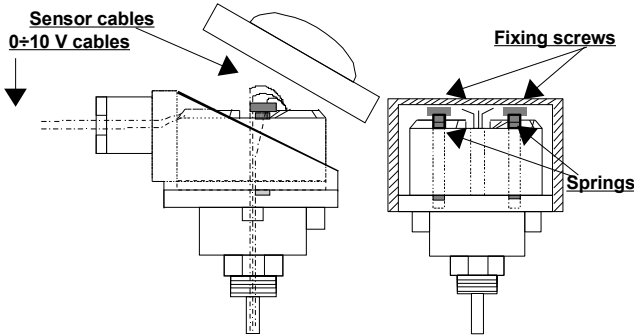

MECHANICAL DIMENSIONS (mm)

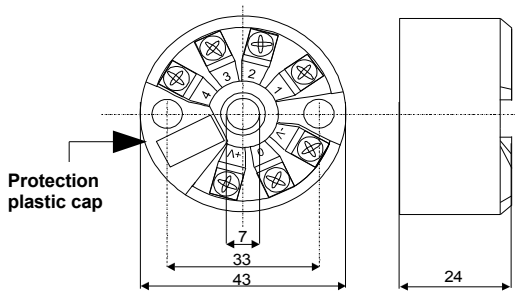

The symbol reported on the product indicates that the product itself must not be considered as a domestic waste. It must be brought to the authorized recycle plant for the recycling of electrical and electronic waste. For more information contact the proper office in the user's city , the service for the waste treatment or the supplier from which the product has been purchased.

HOW TO ORDER

The DAT1135 is provided as requested on the Customer's order. Refer to the section "Technical specification" to determine input and output ranges. The mounting kit for DIN rail is provided **only on request** with code DIN RAIL. In case of the configuration is not specified, the parameters must be set by the user.

ORDER CODE EXAMPLE:

