

PRESSURE TRANSMITTERS

"Piezoresistive Pressure Sensor"

BCT 110



- Piezoresistive pressure sensor
- High sensitivity
- Standard diaphragm
- Stainless steel case
- EMC and reverse polarity protection
- Analog output: 4...20mA or 0...10VDC
- 100 mbar to 600 bar

Applications

- Pneumatic Systems
- Hydraulic Systems
- Machines Equipments
- Air Cooling – Heating Systems
- Water Technologies
- Automation Applications

BCT Technical Specifications

Pressure Range	100 mbar to 600 bar
Output Signal	4...20mA (2 Wires) , 0...10VDC (3 Wires)
Mechanical Connection	G1, G1/2, G1/4
Power Supply	+12...30 VDC
Accuracy	%0,5
Protection Class	IP65
Operating Temperature	-20°C to +85°C
Housing Material	Stainless steel, Brass
Weight	140 grams

Mechanical Dimension (2 Bar to 400 Bar)

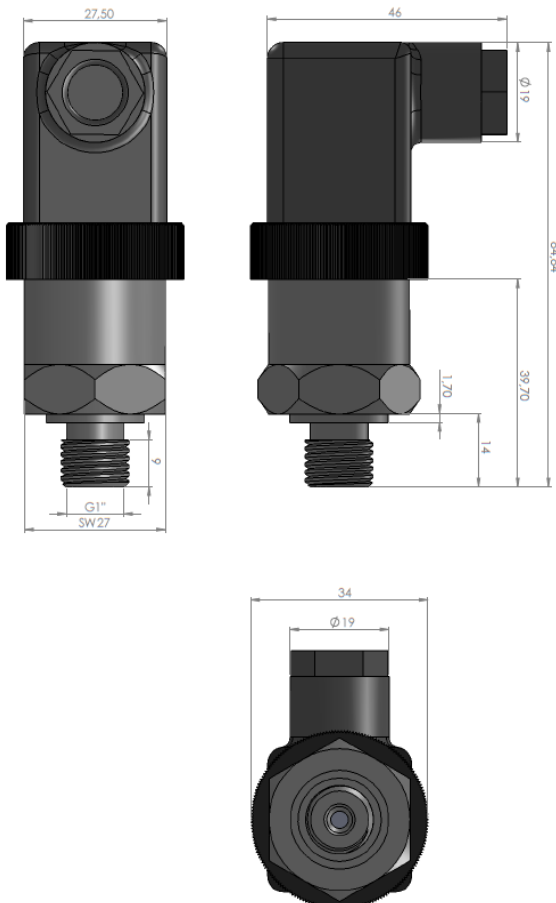

Mechanical Dimension (100 Milibar to 1 Bar and 600 Bar)

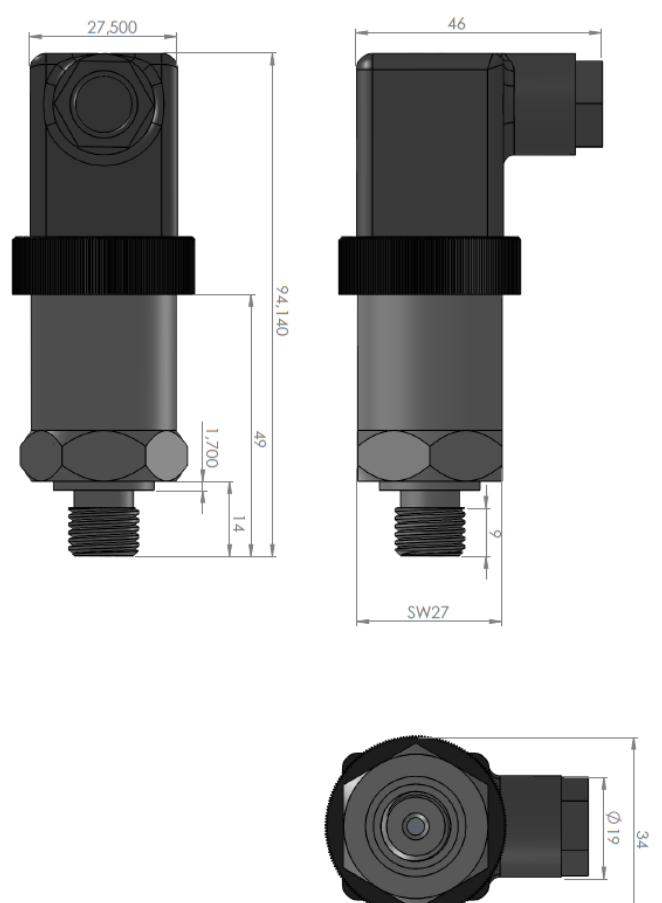

Pin No	Signal
2 Wires 4-20mA Connection	
1	4...20mA Analog Output
2	+12...30 VDC (Supply)

Sample Connection:

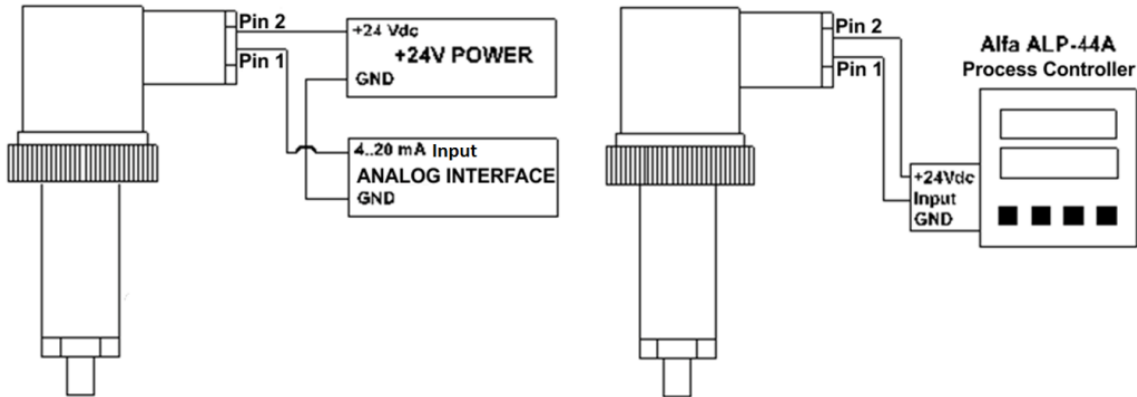

Pin No	Signal
3 Wires 0-10VDC Connection	
1	GND
2	+12...30 VDC (Supply)
3	0...10VDC Analog Output

Sample Connection:

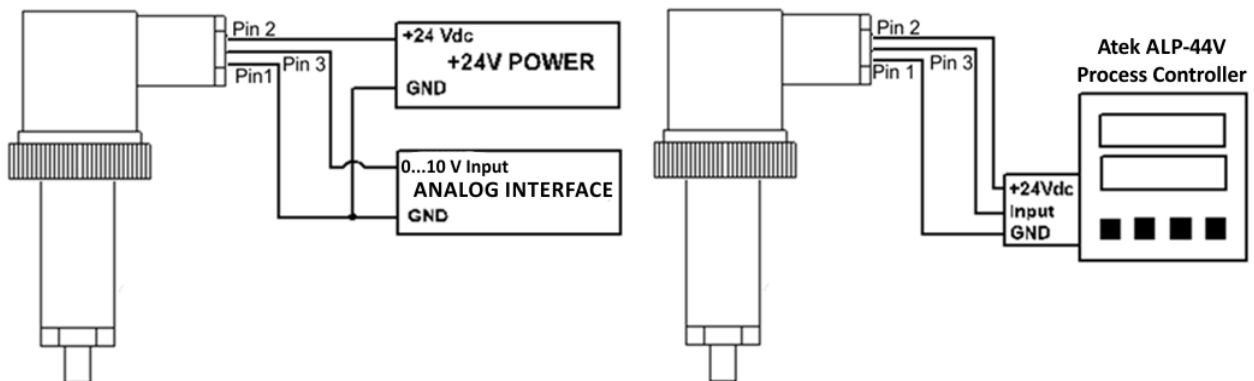

Order Code

Model

BCT 110

Output Signal

V : 0-10 VDC Analog Voltage
A : 4-20 mA Analog Current

V

Electrical Connection

S : DIN43650 Female Socket
1M : 1 Metre Cable
2M : 2 Metre Cable
* Please ask for others

S

Pressure

100mB : 100 Milibar
16B : 16 Bar
600B : 600 Bar

* Between 100 milibar to 600 Bar

Mechanical Connection

G1/4 : G1/4 Connection
G1 : G1 Connection
G1/2 : G1/2 Connection

* Please ask for other mechanical connections

Tempcon Instrumentation Ltd

Tempcon Instrumentation Ltd, Ford Lane Business Park, Ford, West Sussex, UK

Tel: +44(0)1243 558270

Fax: +44(0)1243 558277

www.tempcon.co.uk

info@tempcon.co.uk