

Data sheet

Low pressure transmitter for marine applications

MBS 9300



Compact pressure transmitter programme, MBS 9300 gauge version is designed for use in marine applications e.g. crankcase and turbocharger filters monitoring as well as applications within level measurement.

The programme covers 4 – 20 mA and ratiometric 10-90% of supply output signals, pressure span from 40 – 400 mbar as well as bidirectional ranges.

Excellent vibration stability, robust construction, and a high degree of EMC/EMI protection equip the pressure transmitter to meet the most stringent industrial requirements.

Features

- Compact design
- Full scale span from 40 – 400 mbar
 - bidirectional ranges available, e.g. -40 – 70 mbar etc.
 - lowest zero point –150 mbar
 - max full scale 250 mbar
- Digital temperature compensated
- Output signals 4-20 mA and Ratiometric 10-90% of supply
- Excellent shock and vibration robustness
- Reverse polarity protection
- With build-in clipping function and self-diagnostic features on request
- Enclosure and wetted parts of stainless steel (AISI 316L)
- EU RO Mutual Recognition
- Customer specific versions on request
- For use in Zone 2 explosive atmosphere

Approvals

DNV GL EU RO Mutual Recognition.
Lloyds Register of Shipping, LR
Registro Italiano Navale, RINA
Bureau Veritas, BV
American Bureau of Shipping, ABS
Korean Register of Shipping, KR

Technical data
Performance (EN 60770)

| | | | | | | Units |
|---|----------|---------|---------|----------|---------|--------------------------------------|
| Full-scale span (FSS) | 40 | 60 | 100/140 | 150 | 250/400 | mbar |
| Accuracy @ 25 °C (incl. non-linearity, hysteresis and repeatability) | ≤ ± 2 | ≤ ± 1.5 | ≤ ± 1 | ≤ ± 0.5 | ≤ ± 0.5 | % FSS typ. |
| Non-linearity (BFSL) | ≤ ± 0.2 | ≤ ± 0.2 | ≤ ± 0.2 | ≤ ± 0.2 | ≤ ± 0.2 | % FSS |
| Hysteresis and repeatability | ≤ ± 0.1 | ≤ ± 0.1 | ≤ ± 0.1 | ≤ ± 0.1 | ≤ ± 0.1 | % FSS |
| Total error band (TEB) within compensated temperature range | ≤ ± 5 | ≤ ± 3 | ≤ ± 2 | ≤ ± 1.5 | ≤ ± 1.5 | % FSS |
| Mounting position error for 180° rotation | ≤ ± 1.25 | ≤ ± 0.8 | ≤ ± 0.5 | ≤ ± 0.35 | ≤ ± 0.2 | % FSS |
| Overload pressure (static) | 3.5 | 3.5 | 3.5 | 3.5 | 3.5 | bar |
| Burst pressure | 50 | 50 | 50 | 50 | 50 | bar |
| Response time | | | | | | < 2 ms |
| Resolution | | | | | | Infinite |
| Durability P: 10 – 90% FS | | | | | | 10 × 10 ⁶ pressure cycles |

Full-Scale Span (FSS) is the difference between the upper limit and the lower limit of the pressure range.
(e.g. for pressure range -30 – 30 mbar, FSS = 60 mbar.)

Electrical specifications

| | | |
|--|--|---------------------------|
| Nom. output signal (short circuit protected) | 4 – 20 mA | Ratiometric 10-90% supply |
| Supply voltage [U _B], reverse polarity protected | 9 – 32 V DC | 5 V DC +/- 10% |
| Supply voltage dependency | < ± 0.05% FSS / 10 V | - |
| Load [R _L] (load connected to 0V) | R _L ≤ (U _B - 8 V) / 0.02 A | R _L ≥ 1.5 kΩ |
| Supply current consumption | - | ≤ 6 mA |
| Sink / Source | - | 3.3 mA |
| Output impedance | - | ≤ 25 Ω |

Environmental specifications

| | | |
|--|----------------------------|---|
| Media temperature range | FPM gasket | -20 – 100°C |
| | NBR gasket | -25 – 85 °C |
| Ambient temperature range | See page 3 | |
| Compensated temperature range | 0 – 80 °C | |
| Transport / storage temperature range | -40 – 125 °C | |
| EMC - Emission | EN 61000-6-3 and EN61236-1 | |
| EMC Immunity | EN 61000-6-2 and EN61236-1 | |
| Vibration stability | Sinusoidal | 15.9 mm-pp, 2 Hz – 25 Hz 20 g, 25 Hz – 2 kHz |
| | Random | 7.5 g _{rms} , 5 Hz – 1 kHz |
| Shock resistance | Shock | 500 g / 1 ms |
| | Free fall | 1 m |
| Enclosure (depending on electrical connection) | See page 3 | |

Explosive atmospheres

| | | |
|-----------------------------------|---|-----------------------|
| Zone 2 applications ¹⁾ | II 3G Ex nA IIA T3 Gc -10 °C < Ta < +85 °C | EN60079-0; EN60079-15 |
|-----------------------------------|---|-----------------------|

¹⁾ When used in ATEX Zone 2 areas at low temperatures the cable and plug must be protected against impact.

Mechanical specifications

| | |
|-------------------------|-------------------------------|
| Net weight | 0.2 – 0.3 kg |
| Electrical connector | See page 3 |
| Pressure connection | see page 3 |
| Materials, wetted parts | EN 10088; 1.4404 (AISI 316 L) |

Dimensions / Combinations

| Type code: Electrical connection | A1 | A6 | A9 |
|----------------------------------|---|--|--|
| | EN 175301-803-A, Pg 9 | EN 175301-803-A, Pg 11 | EN 175301-803-A, Pg 13.5 |
| | | | |
| | | | |
| | | | |
| Type code: Pressure connection | FA09 DIN 3852-E-M 14x1.5, Gasket: DIN 3869-14 | GB08 DIN 3852-E-G½ Gasket: DIN 3869-21 | GB04 DIN 3852-E-G1/4 Gasket: DIN 3869-14 |
| Recommended torque: | 20 – 25 Nm | | |

Electrical connection

| Type code: | A0, A1, A6 and A9 |
|---|--|
| | EN 175301-803-A |
| | |
| Ambient temperature | -25 – 100 °C (ATEX zone 2 = -10 – 85 °C) |
| Enclosure | IP65 |
| Materials | Glass filled polyamid, PA 6.6 |
| Electrical connection 4 –20 mA (2 wire) | Pin 1: + supply Pin 2: - supply Pin 3: Not used Earth: Connected to transmitter enclosure |
| Electrical connection Ratiometric 10 - 90% of supply | Pin 1: + supply Pin 2: - common Pin 3: Output Earth: Connected to transmitter enclosure |

For proper ventilation of atmospheric reference pressure a vented cable is recommended.

Recommended mounting position

Error due to different mounting than recommended can be eliminated by zeroing in user hardware

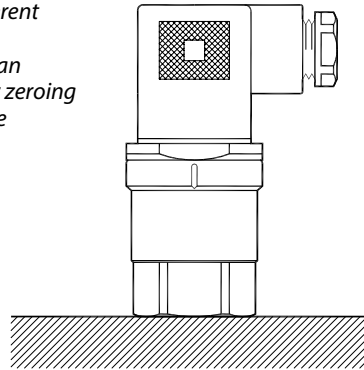

See mounting position error for 180° rotation on page 2

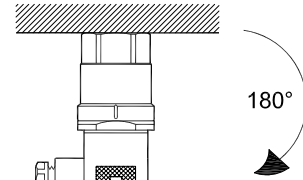

Danfoss
80C476.10

Ordering

| Type 9300 | | Gasket | |
|--------------------------------|-----|---------|---|
| Pressure range | | 1 | Gasket, FPM |
| -20 – 20 mbar | A 1 | 2 | Gasket, NBR |
| -30 – 30 mbar | A 2 | | |
| -70 – 70 mbar | A 3 | | |
| 0 – 40 mbar | B 1 | | |
| 0 – 60 mbar | B 2 | | |
| 0 – 100 mbar | B 3 | | |
| 0 – 150 mbar | B 4 | | |
| 0 – 250 mbar | B 5 | | |
| Pressure reference | | | Pressure connection |
| Gauge (relative) | 1 | G B 0 8 | DIN 3852-E-G1/2, gasket DIN 3869-21 |
| Output signal | | G B 0 4 | DIN 3852-E-G1/4, gasket DIN 3869-14 |
| 4 - 20 mA | 1 | F A 0 9 | DIN 3852-E-M14 x1.5, gasket DIN 3869-14 |
| Ratiometric 10 - 90% of supply | 6 | | |
| | | | Electrical connection |
| | | A 0 | No plug (EN175301-803-A) |
| | | A 1 | Plug Pg 9 (EN 175301-803-A) |
| | | A 6 | Plug Pg 11 (EN175301-803-A) |
| | | A 9 | Plug Pg 13.5 (EN175301-803-A) |

Non-standard build-up codes on request. However, minimum order quantities may apply. Please contact your local Danfoss office for further information.