

Data sheet

# Pressure transmitter for industrial applications

## MBS 4510



The high accuracy flush diaphragm pressure transmitter MBS 4510 is designed for use in non-uniform, high viscous or crystallizing media within industrial applications, and offers a reliable pressure measurement, even under harsh environmental conditions.

The flexible pressure transmitter programme covers a 4 – 20 mA output signal, absolute or gauge (relative) versions, measuring ranges from 0 – 0.25 to 0 – 25 bar zero and span adjustment. A rotatable plug connection and a G1A conic pressure connection with flush mounted diaphragm.

Excellent vibration stability, robust construction, and a high degree of EMC/EMI protection equip the pressure transmitter to meet the most stringent industrial requirements.

### Features

- Designed for use in severe industrial environments
- Enclosure and wetted parts of acid-resistant stainless steel (AISI 316L)
- Pressure ranges in relative (gauge) or absolute up to 25 bar
- Output signal: 4 – 20 mA
- Temperature compensated and laser calibrated
- Accuracy 0.5% FS
- Zero and span adjustment
- USDA-H1 approved oil filling
- For use in Zone 2 explosive atmosphere

**Technical data**
*Performance (EN 60770)*

Accuracy (incl. non-linearity, hysteresis and repeatability)		≤ ± 0.2% FS (typ.)	
		≤ ± 0.5% FS (max.)	
Non-linearity BFSL (conformity)		≤ ± 0.2% FS	
Hysteresis and repeatability		≤ ± 0.1% FS	
Thermal zero point shift	Measuring range:	0 – 250 mbar	≤ ± 0.4% FS / 10K
		0 – 400 mbar	≤ ± 0.3% FS / 10K
		≥ 0 – 600 mbar	≤ ± 0.2% FS / 10K
Thermal sensitivity (span) shift	Measuring range:	0 – 250 mbar	≤ ± 0.4% FS / 10K
		0 – 400 mbar	≤ ± 0.35% FS / 10K
		≥ 0 – 600 mbar	≤ ± 0.2% FS / 10K
Response time		< 4 ms	
Durability, P: 10 – 90% FS		> 10 × 10 <sup>6</sup> cycles	
Zero point adjustment	Measuring range:	0 – 0.25 to 0 – 10 bar	-5 – 20% FS
		0 – 16 to 0 – 25 bar	-5 – 10% FS
Span adjustment	Measuring range:	0 – 0.25 to 0 – 25 bar	-5 – 5% FS

*Available measuring ranges*

Pressure range [bar]	Max. Overload pressure [bar]	Burst pressure [bar]
-0.25 – 0.50	2	50
0.00 – 0.25	2	50
0.00 – 0.40	2	50
0.00 – 0.60	2	50
0.00 – 1.00	2	50
0.00 – 1.60	8	50
0.00 – 2.50	8	50
0.00 – 4.00	8	50
0.00 – 6.00	20	50
0.00 – 10.00	20	50
0.00 – 16.00	100	100
0.00 – 25.00	100	100

*Electrical specifications*

Nom. output signal (short-circuit protected)	4 – 20 mA
Supply voltage [U <sub>B</sub> ], polarity protected	10 – 30 V DC
Supply voltage dependency	≤ ± 0.1% FS / 10 V
Current limitation (linear output signal up to 1.5 × rated range)	28 mA (typ.)
Load [R <sub>L</sub> ] (load connected to 0 V)	R <sub>L</sub> ≤ (U <sub>B</sub> - 10 V) / 0.02 A [Ω]

**Technical data**  
*(continued)*
**Environmental conditions**

Sensor temperature range	Normal	-40 – 85 °C
	ATEX Zone 2	-10 – 85 °C
Media temperature	115 - (0.35 × ambient temperature)	
Ambient temperature range	-10 – 85 °C	
Compensated temperature range	0 – 80 °C	
Transport / Storage temperature range	-25 – 85 °C	
EMC – Emission	EN 61000-6-3	
EMC – Immunity	EN 61000-6-2	
Insulation resistance	> 100 MΩ at 100 V	
Mains frequency test	Based on SEN 361503	
Vibration stability	Sinusoidal	15,9 mm-pp, 5 Hz – 25 Hz 20 g, 25 Hz – 2 kHz
	Random	7,5 g <sub>rms</sub> , 5 Hz – 1 kHz
Shock resistance	Shock	500 g / 1 ms
	Free fall	1 m
Enclosure (depending on electrical connection)	IP65	

**Explosive atmospheres**

Zone 2 applications	<b>II 3G</b> <b>Ex nA IIA T3 Gc</b> <b>-20C&lt;Ta&lt;85C</b>	EN60079-0; EN60079-15
---------------------	--	-----------------------

When used in ATEX Zone 2 areas at temperatures <-10 °C the cable and plug must be protected against impact

**Mechanical characteristics**

Materials	Wetted parts	EN 10088-1; 1.4404 (AISI 316 L)
	Enclosure	EN 10088-1; 1.4404 (AISI 316 L)
	Electrical connections	Glass filled polyamid PA 6.6
Gasket (above thread)	DIN 3869-33-NBR	
Net weight (depending on pressure connection and electrical connection)	0,4 kg	

Ordering standard

<b>MBS 4510</b>	1 - A1 C B 1 2	
<b>Measuring range</b>		<b>Pressure connection</b> G1A, ISO 228-1, Flush male
0.25 – 0.5 bar	A 4	<b>Electrical connection</b> Plug Pg 9 (EN 175301-803-A)
0 – 0.25 bar	0 4	
0 – 0.4 bar	0 6	
0 – 0.6 bar	0 8	
0 – 1.0 bar	1 0	
0 – 1.6 bar	1 2	
0 – 2.5 bar	1 4	
0 – 4.0 bar	1 6	
0 – 6.0 bar	1 8	
0 – 10 bar	2 0	
0 – 16 bar	2 2	
0 – 25 bar	2 4	
<b>Pressure reference</b>		
Gauge (relative)	1	
Absolute	2	

Preferred version

Electrical connections

Electrical connection	4 – 20 mA output (2 wire)
<p>EN 175301-803-A, Pg 9</p>	<p>Pin 1: + supply Pin 2: ÷ supply Pin 3: Not used</p> <p>Earth: Connected to MBS enclosure</p>

Dimensions

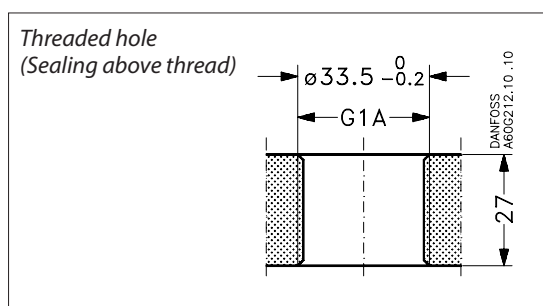
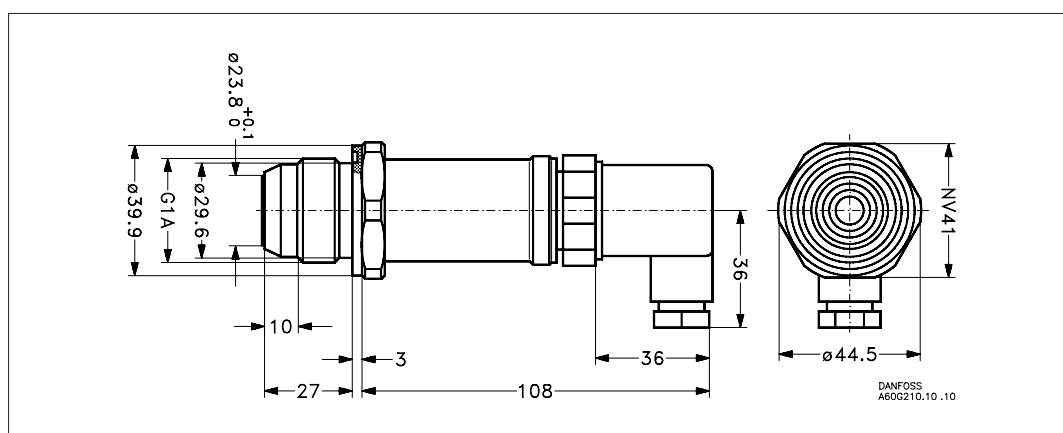

### Installation

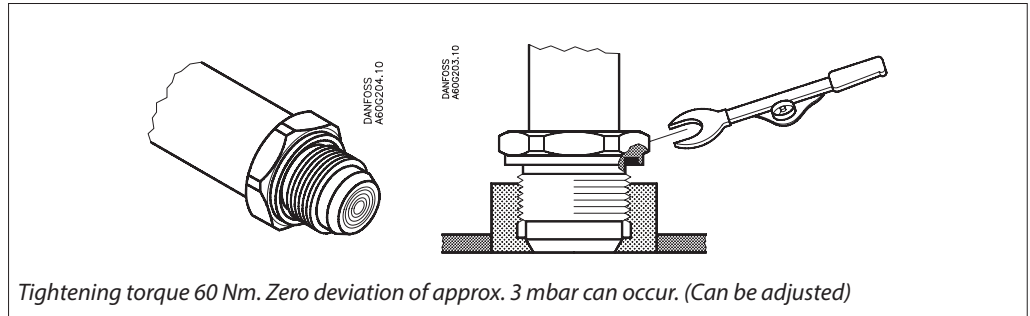

### Adjustment

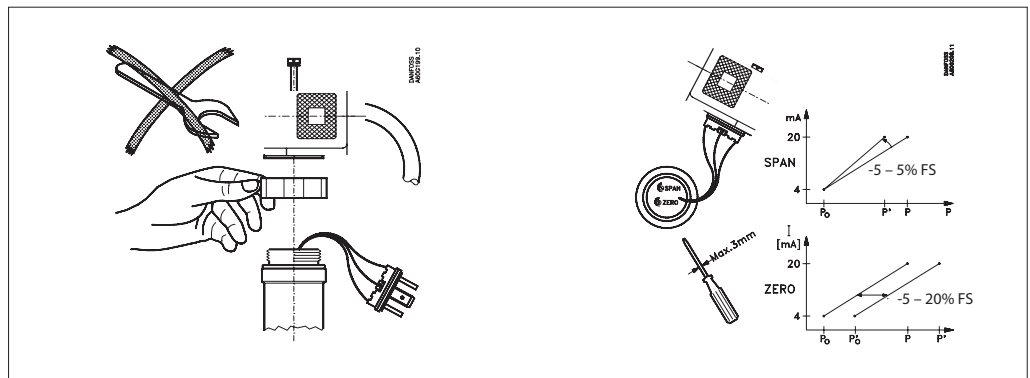

### Accessories

<p>Welding nipple for conic metal/metal seal <b>Code no.: 060G2501</b></p>	<p>DIN 11851 (dairy connection), DN40 <b>Code no.: 060G2505</b></p>
<p>DIN 11851 (dairy connection), DN50 <b>Code no.: 060G2506</b></p>	<p>Clamp, ISO 2852, 1½ in. <b>Code no.: 060G2502</b></p>
<p>Clamp, ISO 2852, 2 in. <b>Code no.: 060G2510</b></p>	<p>SMS 1145 connection, 1½ in. <b>Code no.: 060G2503</b></p>